

Stylebook



Since 1967, italian doors manufactures...

[Download our product catalogue](#)



...to live and work in beautiful, harmonious and comfortable spaces.





Since 1967, Barausse has specialized in the production of interior doors, which are 100% designed and manufactured in Italy.

Barausse develops and offers furnishing solutions for the purpose of creating a separate space which is both functional and prestigious with a high esthetical value. The result is both a beautiful and comfortable place to live!

Thanks to multiple certifications of our fire rated doors, the ability to design bespoke products and our over twenty years of experience in the contract field, Barausse is able to provide worldwide, a high quality product for luxury hotels. We also provide this same high end standard for public buildings, high rise residential and private homes.

Barausse is a Company born in Veneto, an Italian territory that stands out for its innovation, hard work, efficiency, inventiveness. Venezia, Vicenza, Verona, Padova Treviso, Rovigo and Belluno are proof of a magnitude that has been able become concrete in the field of art and architecture.

Dal 1967 Barausse è specializzata nella produzione di porte per interni, 100% progettate e realizzate in Italia. Barausse sviluppa e propone soluzioni d'arredo funzionali alla separazione degli spazi, di alto prestigio e valore estetico, per creare ambienti dove vivere sia un'esperienza emozionante e confortevole. Forte di numerose certificazioni per porte resistenti al fuoco, della progettazione di prodotti custom, e la ventennale esperienza nel settore contract, Barausse opera nel mondo nella realizzazione di Hotel di lusso, strutture pubbliche, costruzioni residenziali e ville private. Barausse è un'azienda nata nel Veneto, un territorio italiano che si distingue per le sue caratteristiche di innovazione, operosità, efficienza, ingegno. Venezia, Vicenza, Verona, Padova Treviso, Rovigo e Belluno sono la testimonianza di una grandezza che ha saputo divenire concreta anche nel campo dell'arte e dell'architettura.

DESIGN

Moderno



GRAFFIATA - IOSA GHINI COLLECTION - p. 6



EAN - BELLUNATO COLLECTION - p. 24



TABACCO - p. 40



MASAI - p. 54

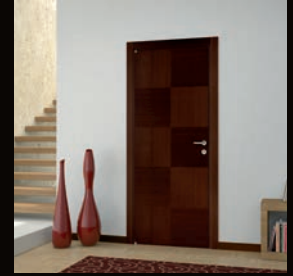

WENGE - p. 70



NODO - IOSA GHINI COLLECTION - p. 10



GEMMA - BELLUNATO COLLECTION - p. 28



ICE - p. 42



CANALETTO - p. 56



BLANC / COLOR - p. 72



PIA - IOSA GHINI COLLECTION - p. 12



VALZER - BELLUNATO COLLECTION - p. 30



VANILLA - p. 46

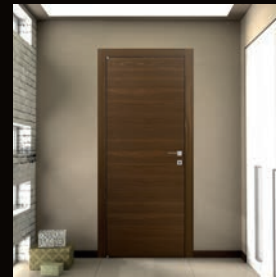

OLMO - p. 60



SHINY - p. 74



OTTAGONO - BELLUNATO COLLECTION - p. 16



GEOMETRIA - BELLUNATO COLLECTION - p. 32

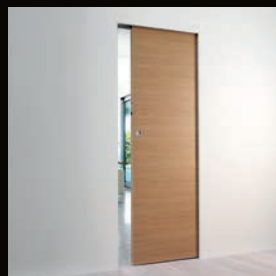

MIELE - p. 48



GRALLEY - p. 62



BIT - BELLUNATO COLLECTION - p. 20



BAKLITE - p. 34

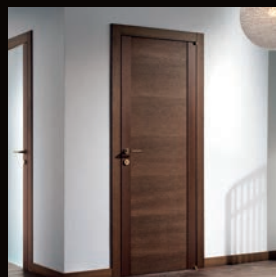

CACAO - p. 50



NOCE - p. 66

Classica

SYSTEMS



TIEPOLO · p. 80



ANTICA VENEZIA · p. 96



INVISIBLE FRAME SECRET2 · p. 108

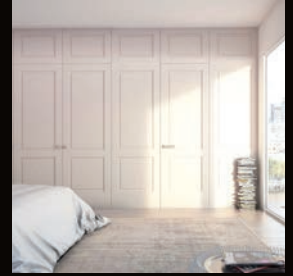

DOORS & WALL PANELLING · p. 128



TIZIANO · p. 84



PALLADIO · p. 100



INVISIBLE RAIL FILA · p. 116



ARMOURED DOORS · p. 132



BURANO · p. 86



PALLADIO 120 · p. 102

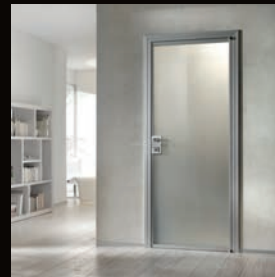

ALUMINIUM HINGED DOORS · p. 118



BARAUSSE FOR CONTRACT · p. 134



CANOVA · p. 90



OPEN · p. 104



LEAVES WITH ALUMINIUM PROFILES · p. 122



CERTIFIED TECHNOLOGY · p. 138



DOGE · p. 92



SLIDING SOLUTIONS · p. 124

ITALIAN DESIGNER DOORS



GRAFFIATA

BLANC, COLOR, MIELE, CACAO

iosaghini collection

Massimo Iosa Ghini

DESIGNER

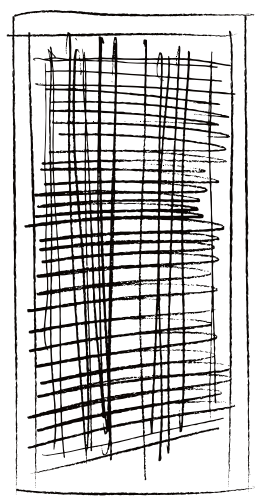
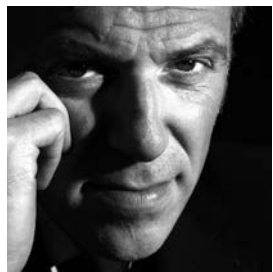



MIELE GRAFFIATA INVERSO

Fire rated option

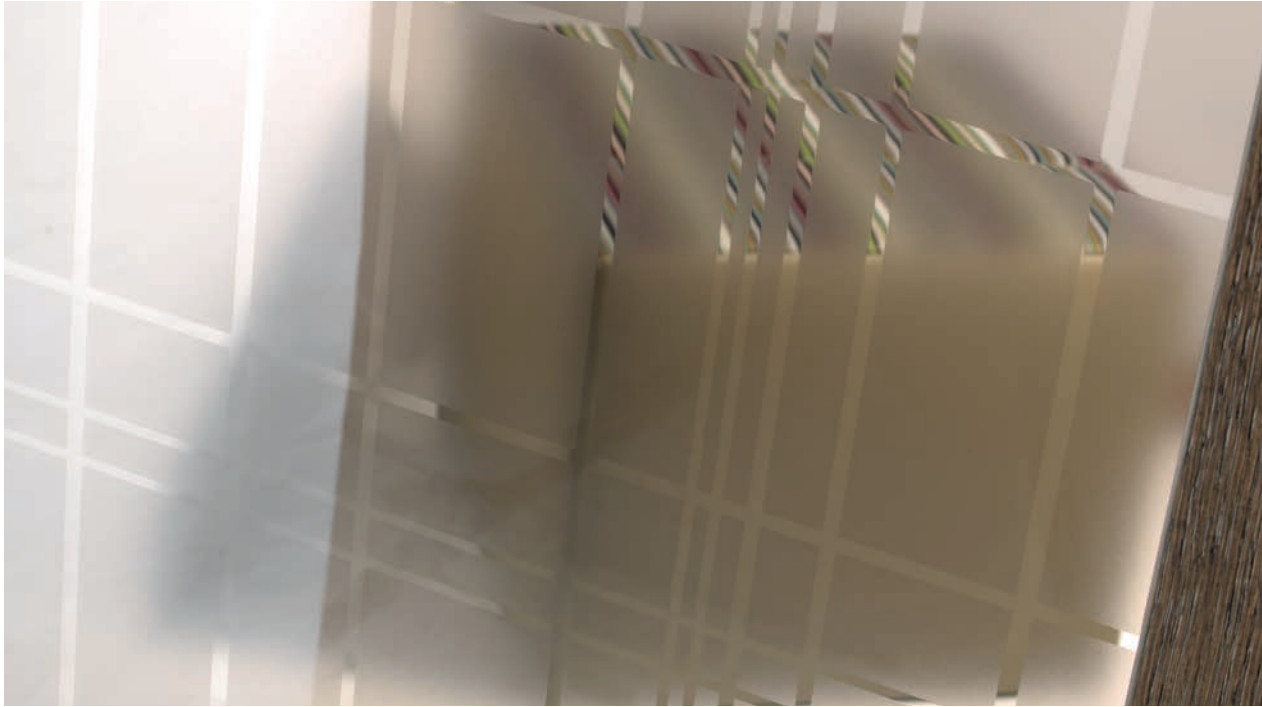

CACAO RVU SM05

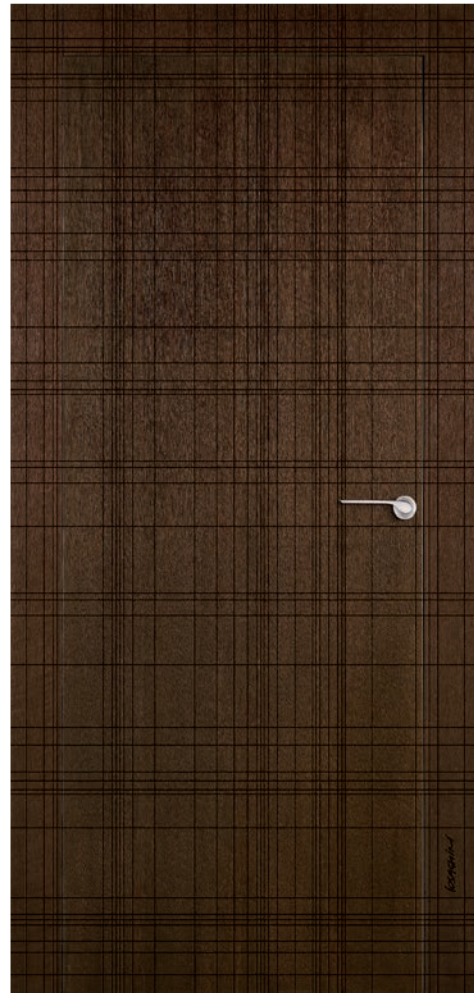

CACAO GRAFFIATA INVERSO
Fire rated option

iosaghini collection



BLANC GRAFFIATA
Fire rated option



NODO

CACAO

iosaghini collection



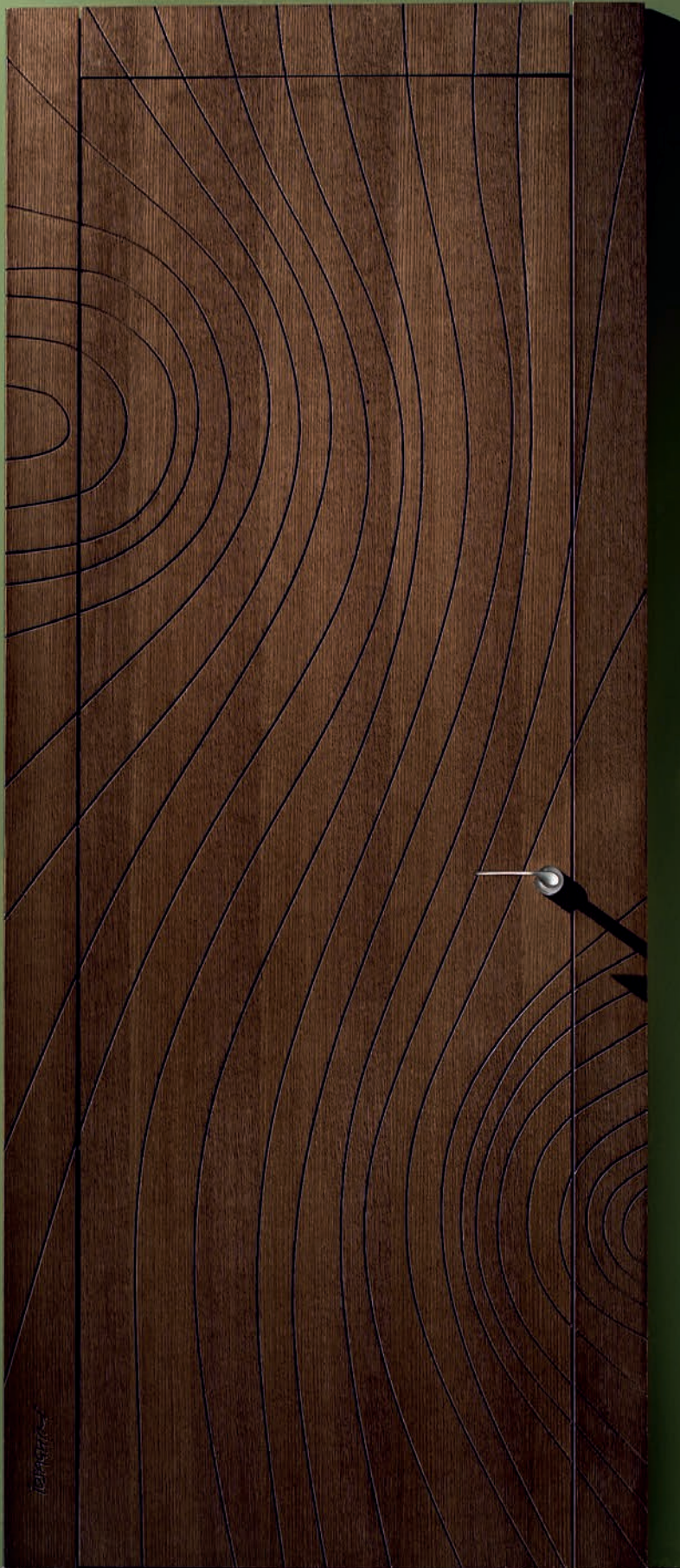

CACAO NODO INVERSO

Fire rated option

ITALIAN DESIGNER DOORS



PIA

GENUINE LEATHER



iosaghini collection



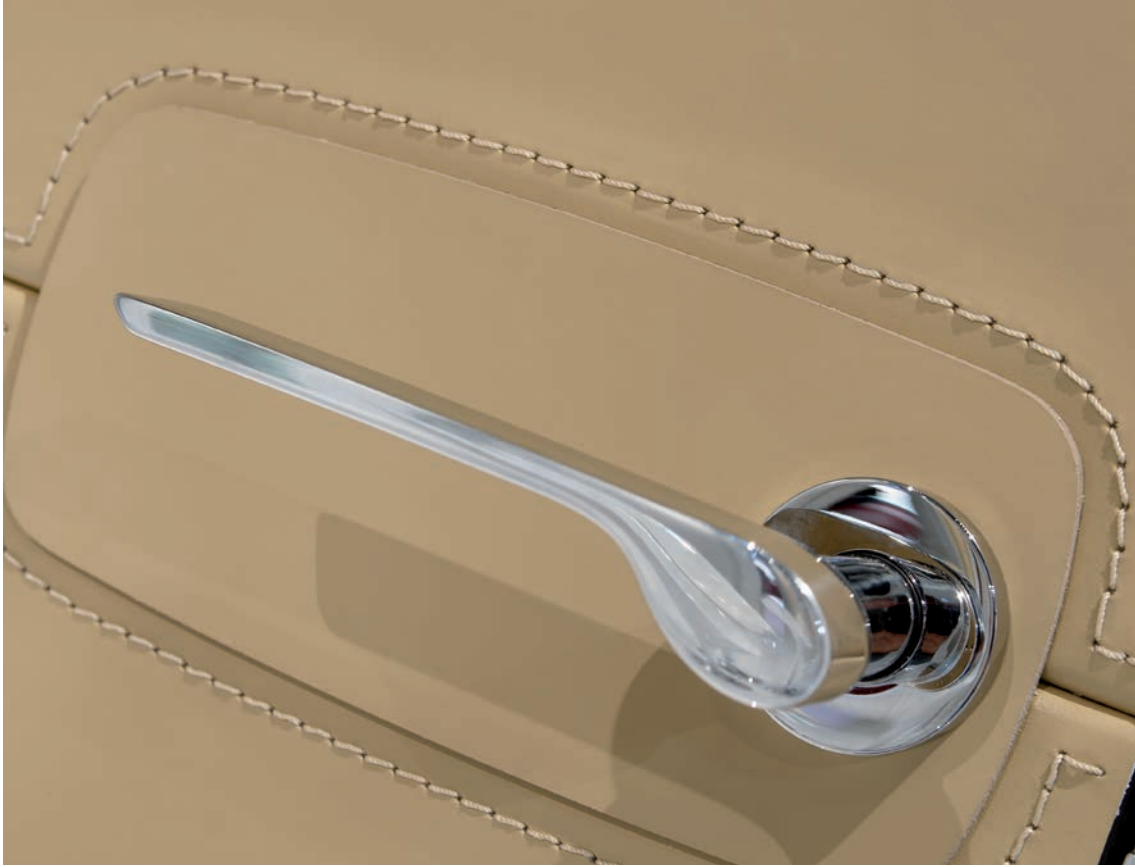

iosaghini collection



PIA N

ITALIAN DESIGNER DOORS



OTTAGONO

BLANC, COLOR

BELLUNATO Collection

Massimo Bellunato

DESIGNER

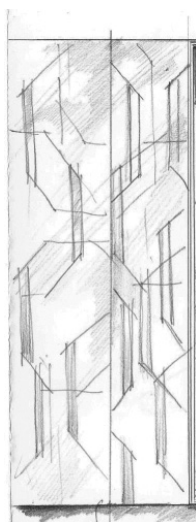



COLOR OTTAGONO SECRET2



COLOR OTTAGONO SECRET2



BLANC OTTAGONO
Fire rated option



BLANC OTTAGONO INNER

BIT

BLANC, COLOR, MIELE



BELLUNATO Collection



MIELE BIT SECRET2, FILA & RAS



MIELE BIT



BLANC BIT INNER



COLOR BIT SECRET2

BELLUNATO Collection

ITALIAN DESIGNER DOORS



EAN

BLANC, COLOR, MIELE

BELLUNATO Collection

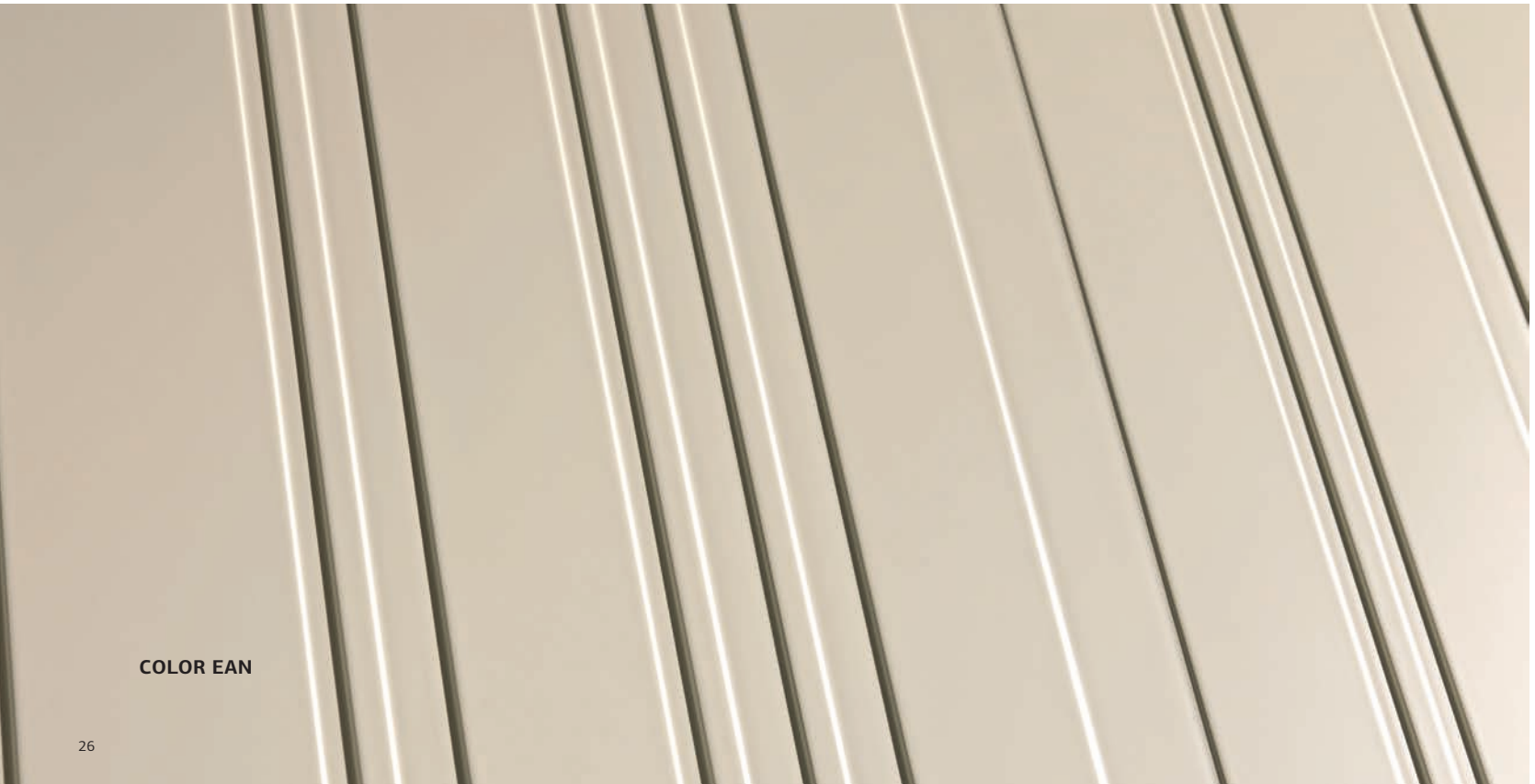

COLOR EAN





MIELE EAN



MIELE EAN INNER

BELLUNATO Collection

ITALIAN DESIGNER DOORS

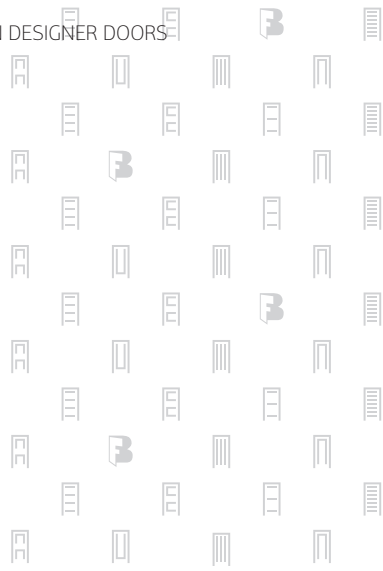

GEMMA

BLANC, COLOR, 1670

BELLUNATO Collection

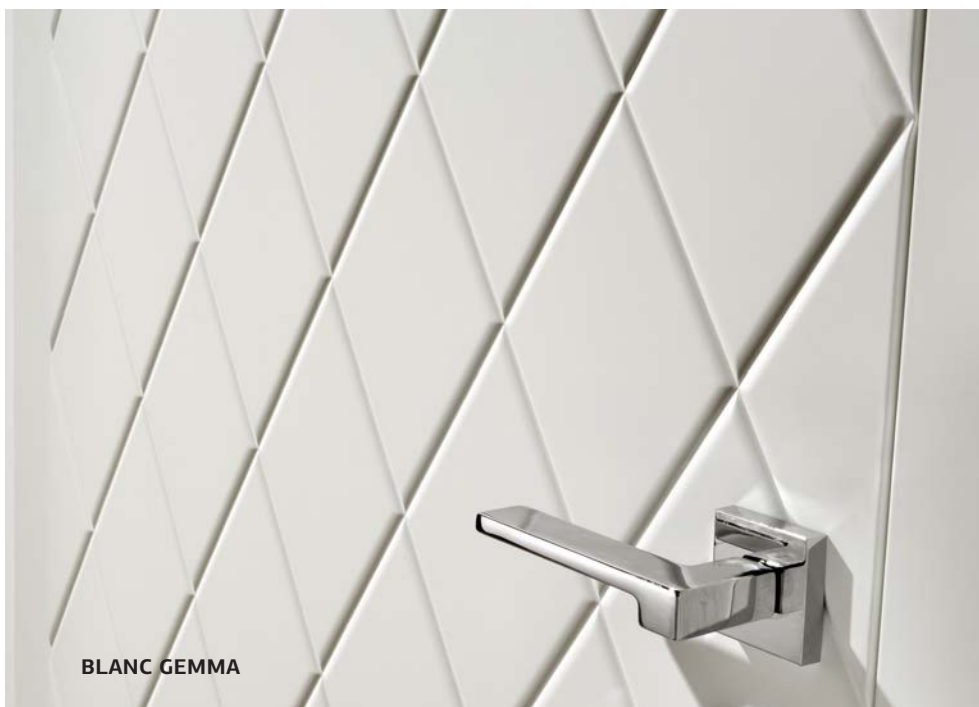

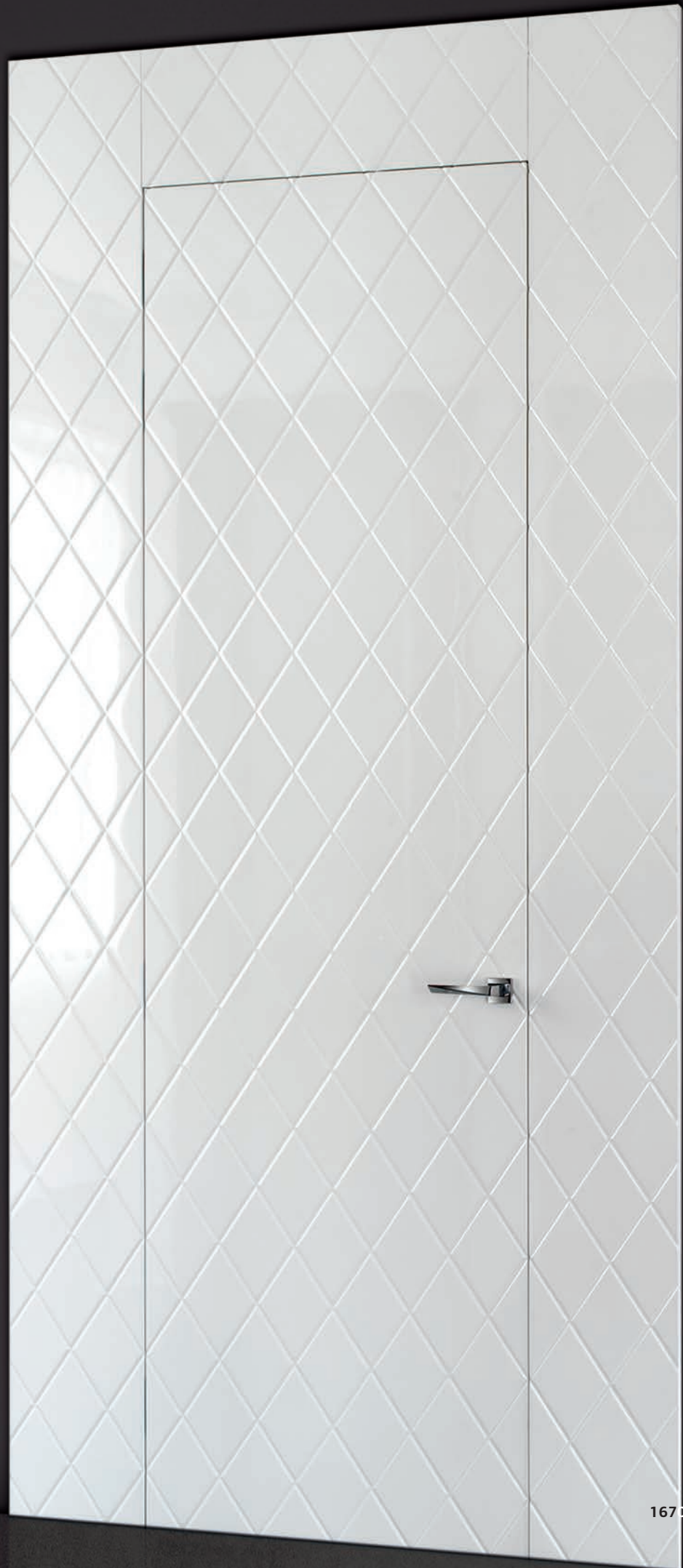

1670 GEMMA TB25
Fire rated option

ITALIAN DESIGNER DOORS



VALZER

BLANC, COLOR

BELLUNATO Collection





BLANC VALZER INNER2

ITALIAN DESIGNER DOORS



GEOMETRIA

BLANC, COLOR

BELLUNATO Collection

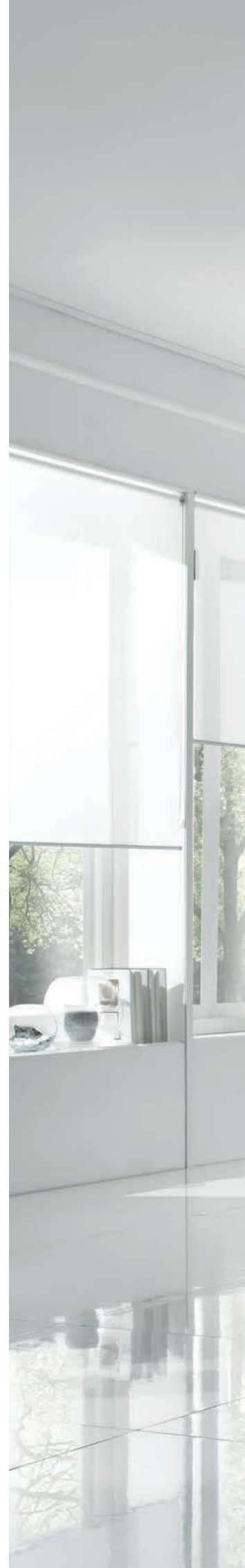



BLANC GEOMETRIA P
Fire rated option

ITALIAN DESIGNER DOORS



BAKLITE

concrete effect
effetto cemento





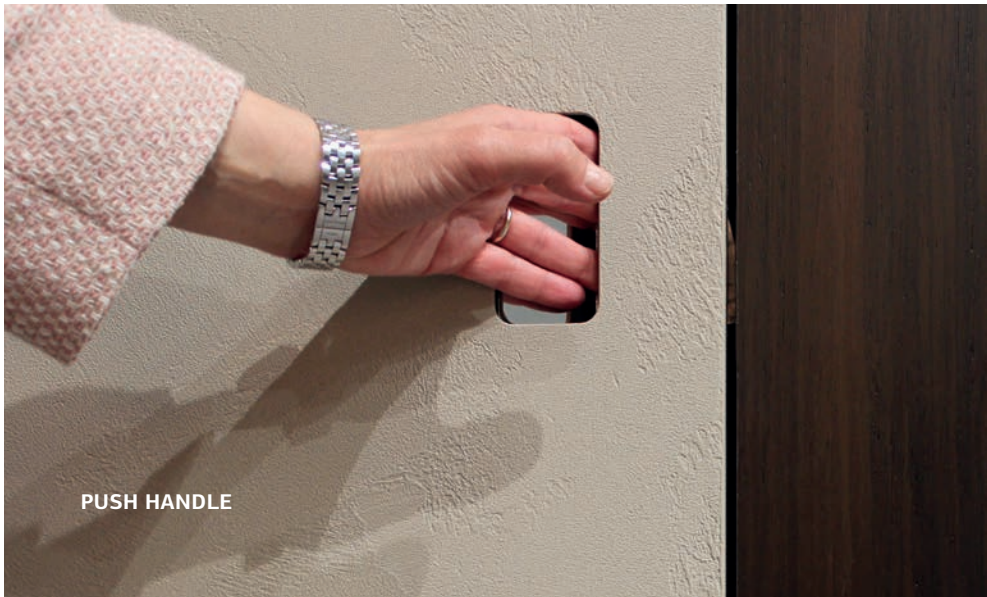
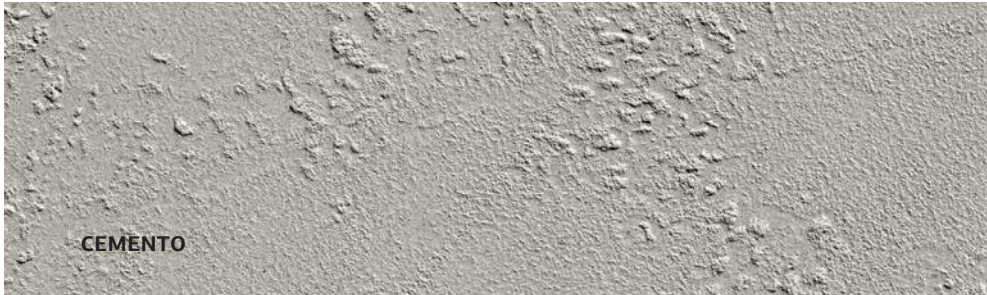
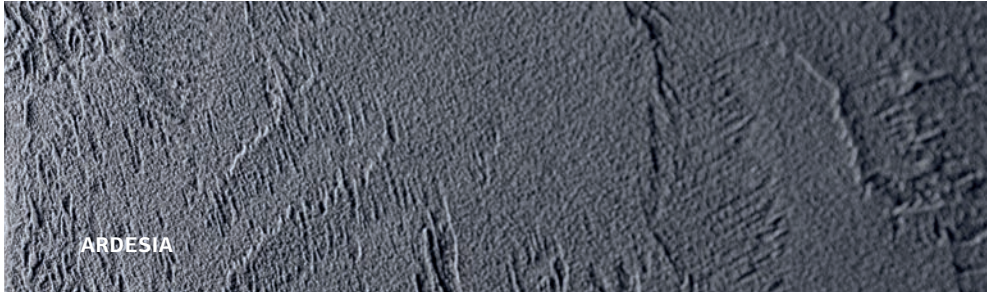







ARDESIA IN SECRET2

TABACCO

spessart heat treated oak
rovere spessart termotrattato





TABACCO IN & WALL PANELLING



ICE

BLANC/COLOR brushed ash
frassino BLANC/COLOR spazzolato





ICE ON

Fire rated option





ICE ONDA RING

ITALIAN DESIGNER DOORS

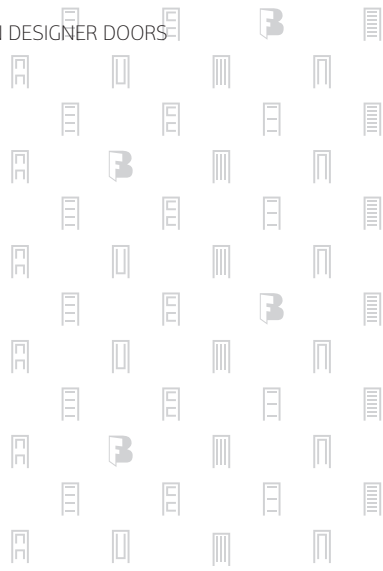

VANILLA

bleached brushed oak
rovere sbiancato spazzolato



VANILLA ONYA





VANILLA ON

Fire rated option



MIELE

natural brushed oak
rovere naturale spazzolato



MIELE ON RAS







CACAO

cocoa brushed oak
rovere cacao spazzolato





CACAO RIVER & RIV-ON



CACAO ON SECRET2



CACAO RIV-PN

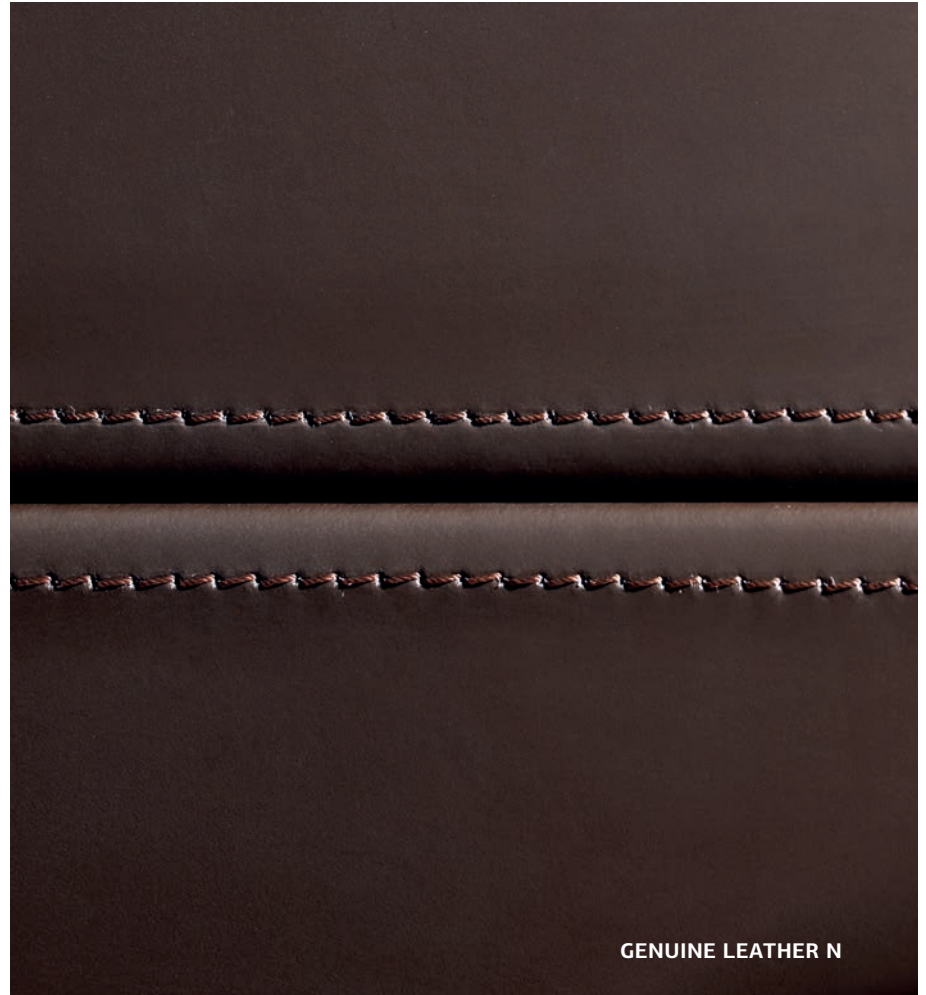

GENUINE LEATHER N

ITALIAN DESIGNER DOORS



MASAI

black brushed oak
rovere nero spazzolato





MASAI ON

Fire rated option

ITALIAN DESIGNER DOORS



CANALETTO

black walnut
noce canaletto





CANALETTO ON INNER



CANALETTO ON RING SCI



ITALIAN DESIGNER DOORS



OLMO

elm
olmo



OLMO ON INNER 2





OLMO ON

Fire rated option

ITALIAN DESIGNER DOORS

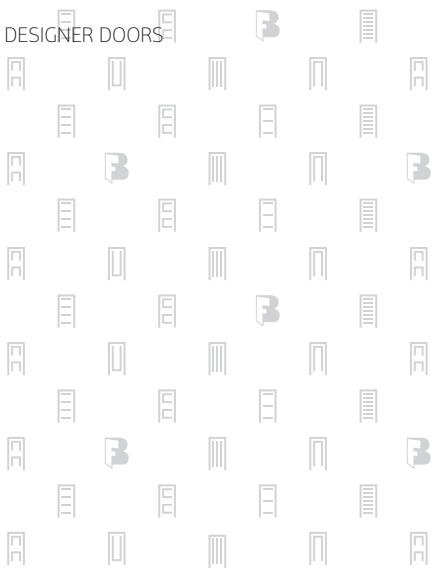

GRALLEY

grey oak
rovere grigio





GRALLEY ON & WALL PANELLING
Fire rated option



GRALLEY ON INNER



GRALLEY 6P
Fire rated option



GRALLEY 6P & WALL PANELLING
Fire rated option

NOCE

1300 - american walnut

1300 - noce americano





NOCE ON

Fire rated option





NOCE KT & KVV
Fire rated option

ITALIAN DESIGNER DOORS



WENGE

wenge
wengé





WENGE PQ

Fire rated option

ITALIAN DESIGNER DOORS



BLANC/COLOR

lacquered
laccato



BLANC TRATTO 10



ITALIAN DESIGNER DOORS



SHINY

shiny
lucido

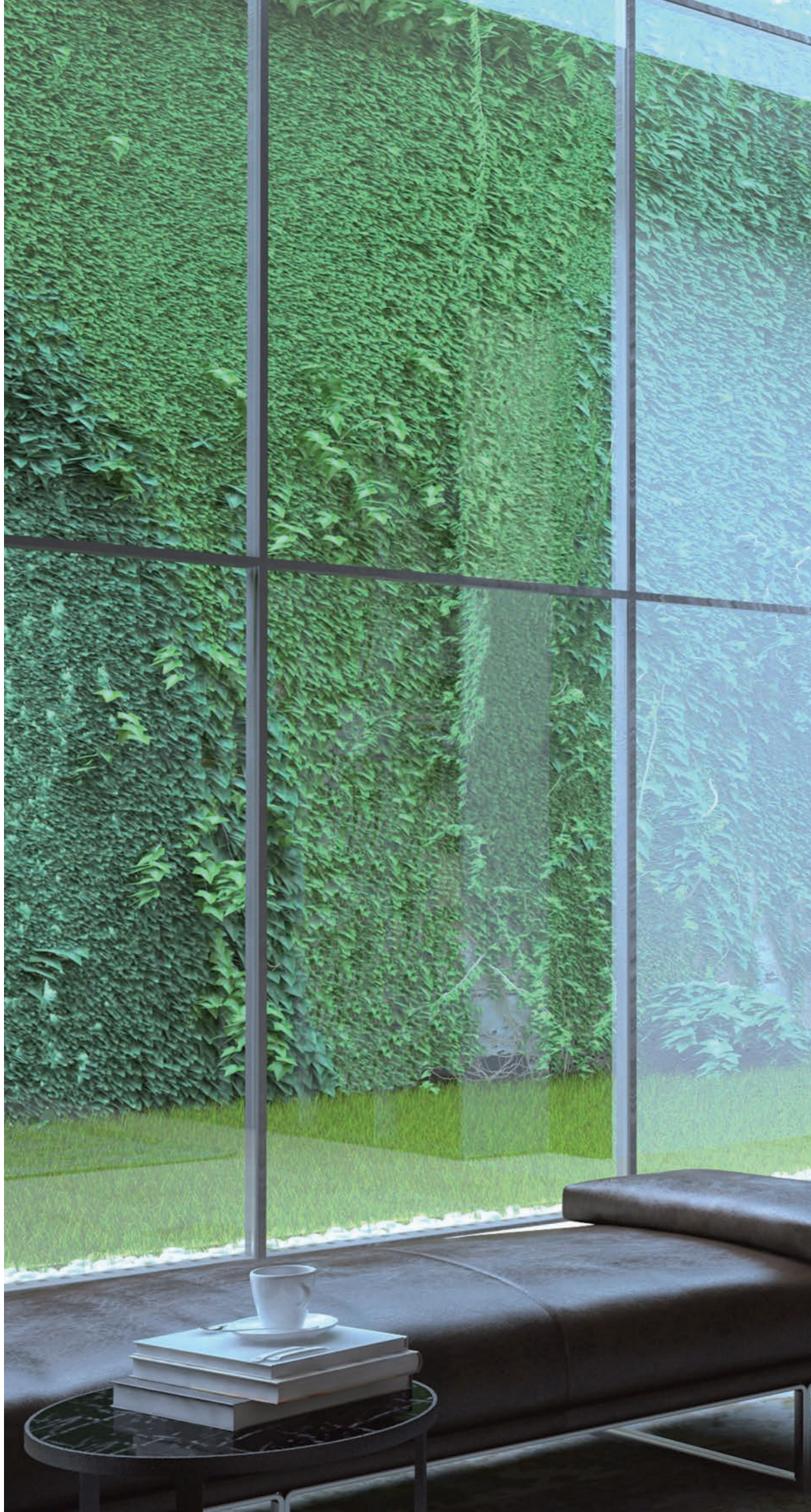



TORTORA ON TB25
Fire rated option



GRIGIO ON

Fire rated option







TORTORA ON
Fire rated option

Tiepolo

1400, 1600, MAGNOLIA
1610, 1620, 1630 hand finished





1400 TIEPOLO 2BB & 2VBC



1400 TIEPOLO 2BB



1400 TIEPOLO 1VUG

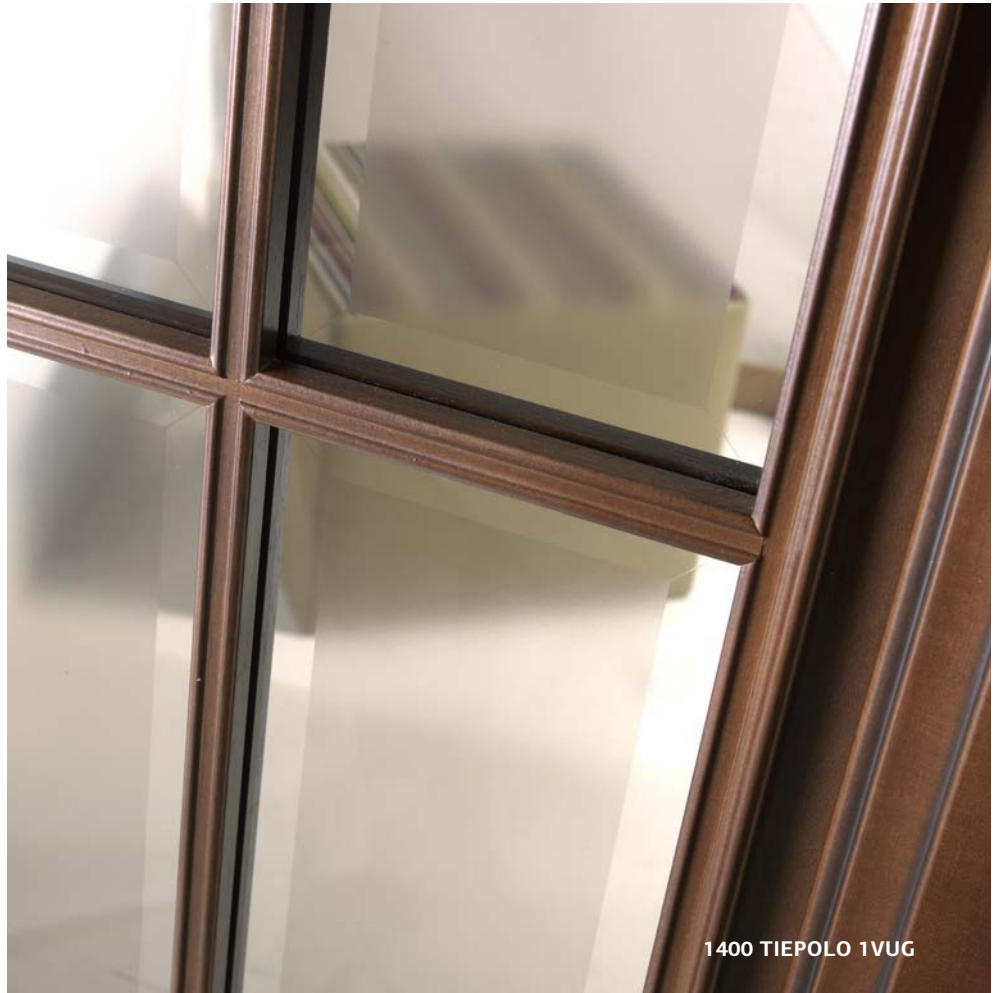

1400 TIEPOLO 1VUG

ITALIAN DESIGNER DOORS



Tiziano

1300 - noce americano
1300 - american walnut





ITALIAN DESIGNER DOORS



Burano

1600, 1670

1610, 1620, 1630 hand finished





1600 BURANO 3P PLUS - GILT FRAMES

Fire rated option



1600 BURANO 3P PLUS - GILT FRAMES

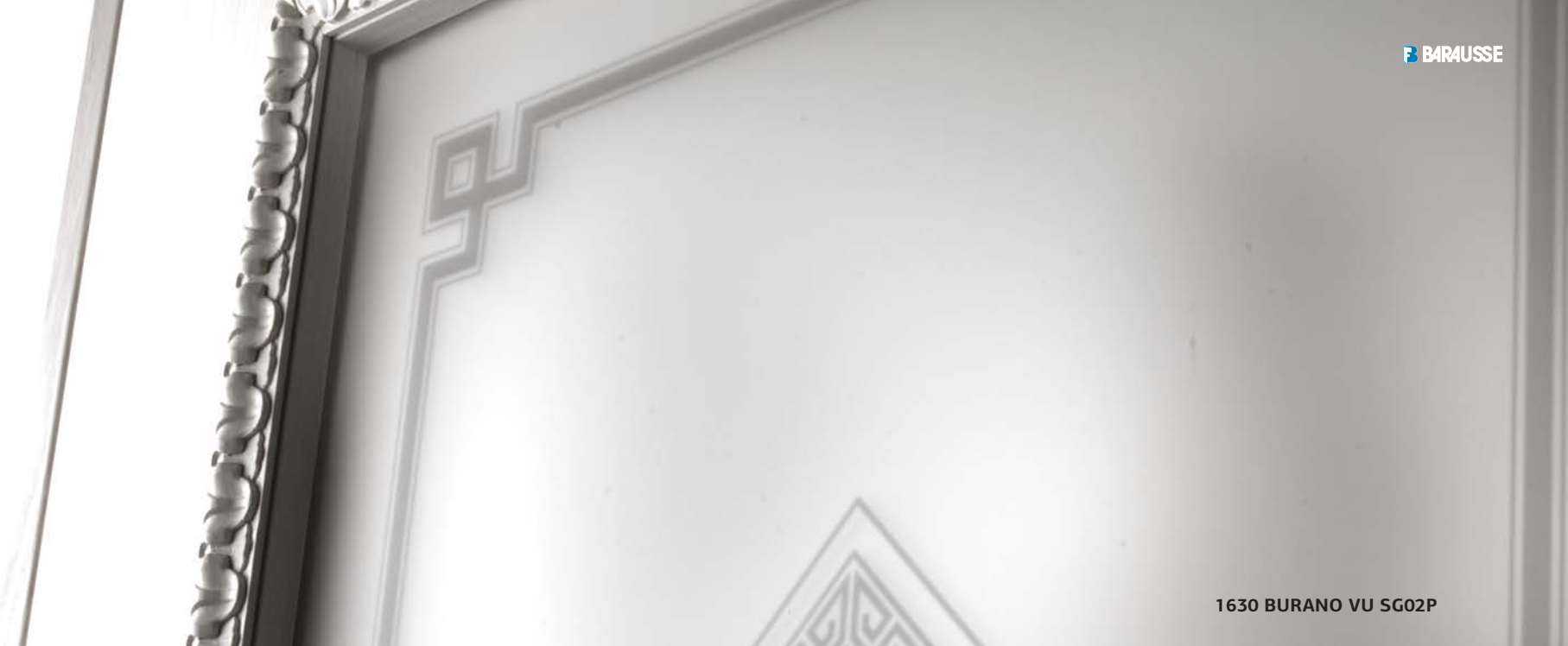

1630 BURANO VU SG02P



1630 BURANO VU SG02P



1610 BURANO PU
Fire rated option

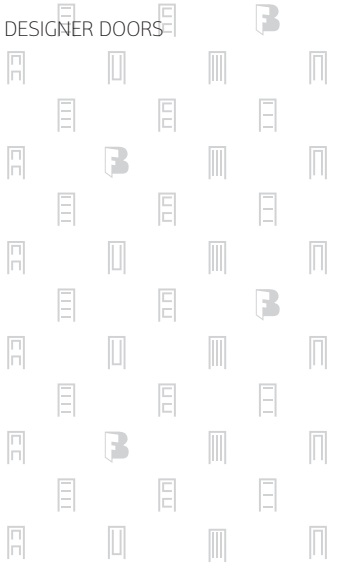

Canova

1600, PANNA, MAGNOLIA, COLOR
1610 hand finished



PANNA CANOVA PPP - GILT FRAMES



Doge

1600, 1670
1610, 1620, 1630 hand finished



1600 DOGE PP & PALLADIO WALL PANELLING

Fire rated option



1600 DOGE PP - HAND PAINTED

1610 DOGE PP - HAND FINISHED



1610 DOGE PP & PLINTH



1620 DOGE PU

Fire rated option

Antica Venezia

1600, 1670

1610, 1620, 1630 hand finished





1610 ANTICA VENEZIA 8G - HAND FINISHED DZ01

Fire rated option





1610 ANTICA VENEZIA 8G
HAND FINISHED DZ01



1600 ANTICA VENEZIA 8G TB

ITALIAN DESIGNER DOORS



Palladio

110, 230, 510





PALLADIO 110 SP
Fire rated option



Palladio 120

MAGNOLIA & gilt frames





PALLADIO 124 PP

Fire rated option

ITALIAN DESIGNER DOORS



Open

MAGNOLIA, AKORI



MAGNOLIA 01PP





MAGNOLIA 01PP



AKORI 15BBBR



AKORI 15BBBR

INVISIBLE FRAME

Secret²

ALL FINISHES





YOU SECRET2





TORTORA ON SECRET2



COLOR SECRET2



COLOR SECRET2 & WALL PANELLING





VANITÀ SECRET2 & COLOR OTTAGONO WALL PANNELLING

INVISIBLE RAIL FILEA

ALL FINISHES





MIELE BIT FILA

ALUMINIUM HINGED DOORS

alluminio
aluminio
алюминий
aluminium



CENTRO 60 RING





CENTRO 60 RING



CENTRO 60 RING



SUDDEN CENTRO 70 RING



NOCE CENTRO 70 INNER2



TABACCO IN MACH2

LEAVES WITH ALUMINIUM PROFILES

ante profilate in alluminio
hojas con perfiles en aluminio
полотна с алюминиевым профилем
vantails avec profils en aluminium
skrzydła profilowane z aluminium

PRO



SID



ER





BIT SID (SPECIAL FINISH)

SLIDING DOORS SOLUTIONS

soluzioni scorrevoli
soluciones para puertas correderas
решения для раздвигающихся дверей
solutions pour portes coulissantes
rozwiązania drzwi suwane





CENTRO 60 FUMÈ VOLTA





LUME J-X

DOORS & WALL PANELLING

boiserie
стеновые панели
boazeria

ALL FINISHES



COLOR ANTICA VENEZIA DOOR, WALL PANELLING & CLOSETS

Fire rated option



Porta integrata su boiserie
Door built into wall panelling
Puerta integrada con boiserie
Стеновые панели интегрированы с дверью
Porte intégrée avec la boiserie
Boazeria połączona z drzwiami

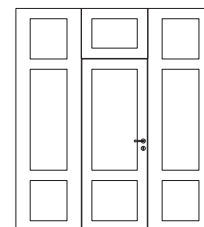
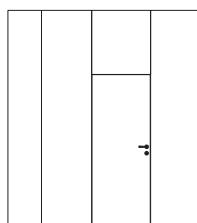

Porta integrata su lambris
Door built into wainscot wall panelling
Puerta integrada con boiserie
Декоративные обшивочные панели
Porte intégrée avec la boiserie
Boazeria w stylu angielskim, czyli do połowy ściany

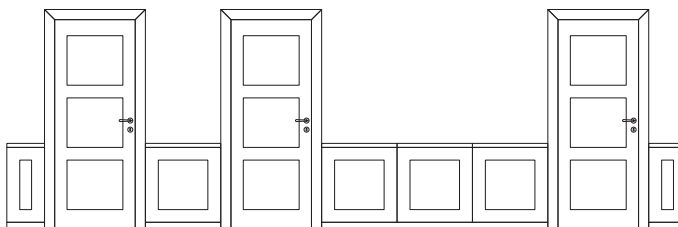



EAN SID MACH2 (SPECIAL FINISH)

ARMOURED DOORS

porte blindate
puertas acorazadas
металлические входные двери
portes blindées
опан cerzone





COLOR GEOMETRIA P



BEST REFERENCES



REINASSANCE TLEMCCEN HOTEL

- Porto Piccolo
- Hilton Molino Stucky
- Hotel Moresco
- Venice Marine
- Verdura Int. Golf & SPA Resort
- IBM Software executive briefing Center
- Yachting Club
- Dolce&Gabbana Offices
- Paradise SPA
- Hospital
- Russian Embassy
- Ukraine Embassy
- Sumitomo Building Residence
- Terrace Ebisu Residence
- Ayohama Rise Residence
- Gazprom Headquarter
- Hyatt Regency Park Hotel Moscow
- Calzedonia Offices and Apartments

- Sistiana (TS), Italy
- Venice, Italy
- Venice, Italy
- Venice, Italy
- Sciaccia (AG), Italy
- Rome, Italy
- Porto Cervo (OT), Italy
- Florence, Italy
- Verona, Italy
- Merano, Italy
- New York, USA
- New York, USA
- Tokyo, Japan
- Tokyo, Japan
- Tokyo, Japan
- Moscow, Russia
- Moscow, Russia
- Moscow, Russia

- InterContinental Tverskaya
- Park Hyatt
- Four Seasons Hotel
- Hyatt Regency Hotel Minsk
- Swiss Hotel Sochi
- Rotterdam Navy Hotel
- Rotterdam Hotel
- Grand Hotel Kempinski & SPA
- Romanos Project
- Constantine Marriott Hotel
- CIC - Centre International Congress
- Sheraton Hotel Algeri
- Reinassance Tlemcen Hotel
- Radisson Blu Hotel
- Townhouses at Lekki
- Central Bank of Armenia
- Al Majda Farm Villa

- Moscow, Russia
- Moscow, Russia
- Moscow, Russia
- Minsk, Russia
- Sochi, Russia
- Rotterdam, Nederland
- Rotterdam, Nederland
- Geneva, Switzerland
- Navarino, Greece
- Constantine, Algeria
- Algeri, Algeria
- Algeri, Algeria
- Tlemcen, Algeria
- Dakar, Senegal
- Lagos, Nigeria
- Yerevan, Armenia
- Qatar

One single partner who takes care of the door requirements in any aspect of the process

- Support in the elaboration of the partner's bid offer
- Project analysis in terms of performance requirements
- Research of the most appropriate technologies
- Elaboration of adequate solutions in the respect of the customer's budget
- Project engineering and elaboration of shop drawings and product data sheet
- Product testing
- Labeling of each item with positioning details
- Customer service and training in jobsite
- Quick solve out to jobsite unexpected problems

Un unico interlocutore che cura la fornitura della porta in ogni aspetto del processo di project management

- Supporto nell'elaborazione dell'offerta di gara del partner
- Analisi del progetto in funzione dei requisiti richiesti
- Ricerca delle tecnologie appropriate
- Elaborazione delle soluzioni adeguate nel rispetto dei budget del cliente
- Project engineering ed elaborazione di shop drawings e schede prodotto
- Collaudo del prodotto
- Identificazione di ogni collo con dettagli di posizionamento
- Assistenza e formazione in cantiere
- Gestione rapida degli imprevisti di cantiere



SPECIAL PALLADIO & LAMBRIS

Fire rated door

GAZPROM HEADQUARTER - MOSCOW, RUSSIA

Interior Plus Contractor

CERTIFIED TECHNOLOGY

IBRF 60 EI₂ 60 / 30 dB



EI₂ 60 - 60 minutes fire rated



30 dB - 30 dB sound proof



UNI EN 1634-1:2001, UNI EN ISO 717/1, UNI EN ISO 140/3



Austria, Belgium, Bulgaria, Croatia, Cyprus, Czech Republic, Denmark, Estonia, Finland, France, Germany, Greece, Hungary, Iceland, Ireland, Italy, Latvia, Lithuania, Luxembourg, Malta, The Netherlands, Norway, Poland, Portugal, Romania, Slovakia, Slovenia, Spain, Sweden, Switzerland, United Kingdom



Knoblock hinges, external slide door closing device, mobile threshold

TPNR 30 EI₁ 30 / 32 dB



EI₁ 30 - 30 minutes fire rated



32 dB - 32 dB sound proof



UNI EN 1634-1:2001, UNI EN ISO 717/1, UNI EN ISO 140/3



Austria, Belgium, Bulgaria, Croatia, Cyprus, Czech Republic, Denmark, Estonia, Finland, France, Germany, Greece, Hungary, Iceland, Ireland, Italy, Latvia, Lithuania, Luxembourg, Malta, The Netherlands, Norway, Poland, Portugal, Romania, Slovakia, Slovenia, Spain, Sweden, Switzerland, United Kingdom



Switzerland VKF
Knoblock hinges, external slide door closing device, mobile threshold

HTB-S2 EI₁ 45 / 30 dB



EI₁ 450 - 45 minutes fire rated



30 dB - 30 dB sound proof



UNI EN 1634-1:2001, UNI EN ISO 717/1, UNI EN ISO 140/3



Austria, Belgium, Bulgaria, Croatia, Cyprus, Czech Republic, Denmark, Estonia, Finland, France, Germany, Greece, Hungary, Iceland, Ireland, Italy, Latvia, Lithuania, Luxembourg, Malta, The Netherlands, Norway, Poland, Portugal, Romania, Slovakia, Slovenia, Spain, Sweden, Switzerland, United Kingdom



Switzerland VKF
Invisible hinges, invisible door closing device, mobile threshold

HTB-S7 EI₁ 30 / 41 dB



EI₁ 300 - 30 minutes fire rated



41 dB - 41 dB sound proof



UNI EN 1634-1:2001, UNI EN ISO 717/1, UNI EN ISO 140/3



Austria, Belgium, Bulgaria, Croatia, Cyprus, Czech Republic, Denmark, Estonia, Finland, France, Germany, Greece, Hungary, Iceland, Ireland, Italy, Latvia, Lithuania, Luxembourg, Malta, The Netherlands, Norway, Poland, Portugal, Romania, Slovakia, Slovenia, Spain, Sweden, Switzerland, United Kingdom



Invisible hinges, invisible door closing device, mobile threshold

HTB-S6 EI₁ 60 / 30 dB



EI₁ 600 - 60 minutes fire rated



30 dB - 30 dB sound proof



UNI EN 1634-1:2009, UNI EN ISO 717/1, UNI EN ISO 140/3



Austria, Belgium, Bulgaria, Croatia, Cyprus, Czech Republic, Denmark, Estonia, Finland, France, Germany, Greece, Hungary, Iceland, Ireland, Italy, Latvia, Lithuania, Luxembourg, Malta, The Netherlands, Norway, Poland, Portugal, Romania, Slovakia, Slovenia, Spain, Sweden, Switzerland, United Kingdom



Invisible hinges, invisible door closing device, mobile threshold

For further certifications, please contact us.



SPECIAL MAGNOLIA & LAMBRIS

Fire rated door

finishes

■ piallaccio di legno
wood veneer
chapa de madera
облицовка шпоном
placage de bois
drewniane okleiny

● piallaccio di legno precomposto
reconstructed wood veneer
chapa de madera precompuesta
облицовка наборным шпоном
placage de bois reconstitué
zrekonstruowany fornir z drewna naturalnego

spazzolato · brushed · cepillado · брашированный · brossé · szczotkowany

TABACCO



rovere spessart termotrattato
spessart heat treated oak
roble spessart tratados
térmicamente
дуб спессарт термообработанный
chêne spessart thermo traité
dąb spessart poddany
obróbce cieplnej

ICE



frassino laccato blanc spazzolato
blanc lacquered brushed ash
fresno lacado blanc cepillado
ясень брашированный
blanc крашенная
frêne laqué blanc brossé
jesion lakierowany blanc
typu szczotkowanego

VANILLA



rovere sbiancato spazzolato
bleached brushed oak
roble blanqueado cepillado
дуб беленый брашированный
chêne cérusé brossé
dąb bielony szczotkowany

MIELE



rovere naturale spazzolato
natural brushed oak
roble natural cepillado
дуб натуральный брашированный
chêne naturel brossé
dąb naturalny szczotkowany

CACAO

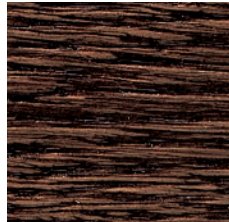

rovere cacao spazzolato
cocoa brushed oak
roble cacao cepillado
дуб брашированный какао
chêne cacao brossé
dąb kakao szczotkowany

MASAI

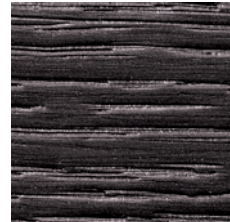

rovere nero spazzolato
black brushed oak
roble negro cepillado
дуб брашированный черный
chêne noir brossé
dąb czarny szczotkowany

essenze · veneers · maderas · материалы · essences · fornir

GRALLEY



rovere grigio
grey oak
roble gris
дуб серый
chêne gris
dąb szary

OLMO

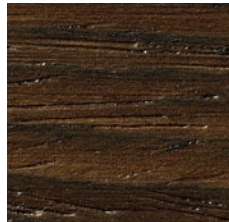

olmo
elm
olmo
вяз
orme
wiąz

CANALETTO



noce canaletto
black walnut
nogal negro
орех каналетто
noyer noir
orzech canaletto

WENGE

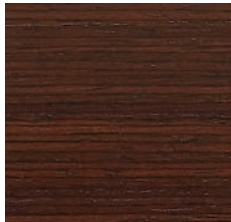

wengé
wenge
wengué
венге
wengé
wenge

AKORI

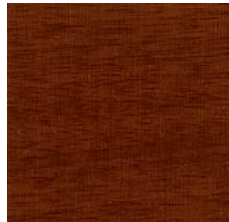

noce akori
akori walnut
nogal akori
орех акори
noyer akori
orzech akori

1300 / NOCE

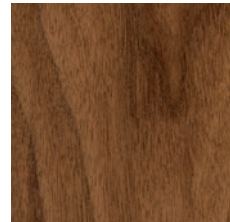

noce americano
american walnut
nogal americano
орех американский
noyer américain
orzech amerykański

1400



noce akori anticato
antique akori walnut
nogal akori antiguo
орех акори античный
noyer akori vieilli
orzech akori antyczny

laccato · lacquered · lacado · крашенная · laqué · lakierowane

BLANC

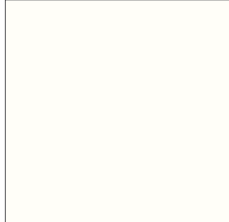

laccato bianco Barausse
Barausse white lacquered
lacado blanco Barausse
белый крашенная Barausse
laqué blanc Barausse
lakierowane białe Barausse

MAGNOLIA

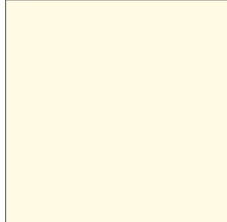

laccato RAL 9010
RAL 9010 lacquered
lacado RAL 9010
RAL 9010 крашенная
laqué RAL 9010
lakierowane RAL 9010

COLOR



laccato colore
colour lacquered
lacado colorado
цветной крашенная
laqué couleur
lakierowane – wersja kolor

1600

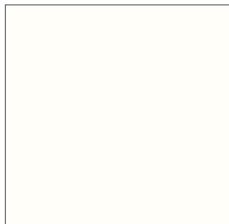

bianco gesso
chalk white
blanco yeso
белый гипс
blanc craquelé
biały gips

1670



bianco brillante
glossy white
blanco brillante
белый блестящий
blanc brillant
biały błyszczący

laccato rifinito a mano · lacquered and hand finished · lacado acabado a mano

крашенный – расписанный вручную · laqué fini à la main · lakierowanie ręczne

1610



avorio patinato
coated ivory
marfil glaseado
слоновая кость патинированная
ivoire patiné
kość słoniowa powlekana
slonovinově bílá patinovaná

1620



crema patinato
coated cream
crema glaseada
кремовый патинированный
crème patiné
powlekany kremowy
krémově bílá patinovaná

1630



tortora patinato
coated turtledove
törtola glaseada
тортора патинированный
tourterelle patiné
gołąb powlekany
šedoběžová patinovaná

finishes

effetto cristallo · crystal effect · efecto de cristal · Эффект стеклянной отделки · effet cristal · efekt krystaliczne

SUGAR



MILK



CARAMEL



CANDY

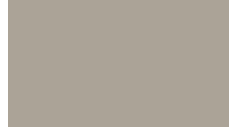

S-SUGAR



S-MILK

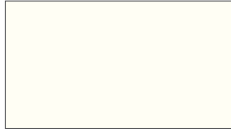

S-CARAMEL



S- CANDY



lucido · shiny · brillante · глянцевый · brillant · polerowane

BIANCO



PANNA



TORTORA



CAPPUCCINO



CHIANTI



NERO

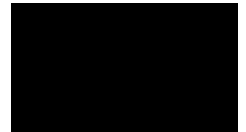

CREMA

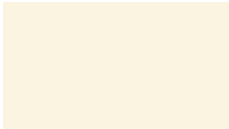

SETA

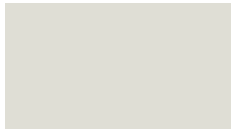

GRIGIO



CAFFÈ



TERRA



resina · resin · resina · смола · résine · żywica

CORDA

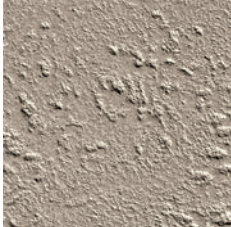

ARDESIA

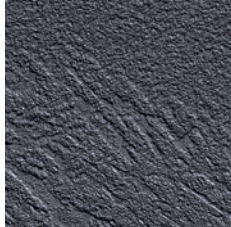

PIETRA



CEMENTO

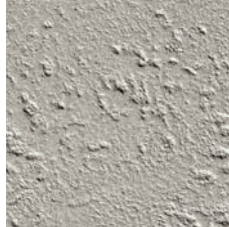

LAB-TESSUTI

STRIPES



SUDDEN 003



SUDDEN 011



SUDDEN 016



SUDDEN 024

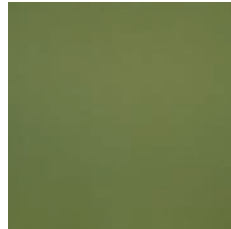

pelle · leather · piel · кожа · cuir · skóra

B



N

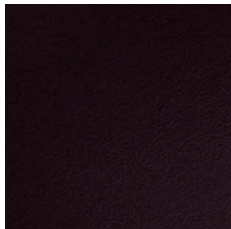

RAVEN

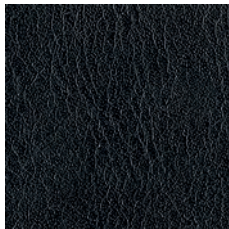

CAYMAN



alluminio · aluminium · aluminio · алюминий · aluminium · aluminium

MATT



SHINY



BRONZE



inox



handles for hinged doors

maniglie per porte a battente

manivelas para puertas batientes

ручки для створчатых дверей

poignées pour portes battantes

klamki dla drzwi otwieranych tradycyjnie

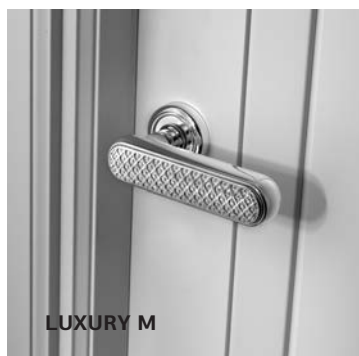
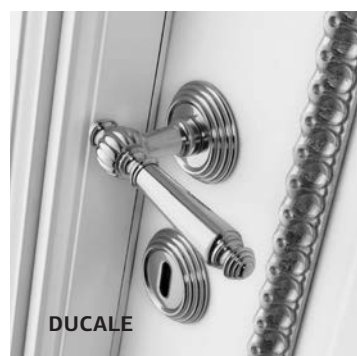
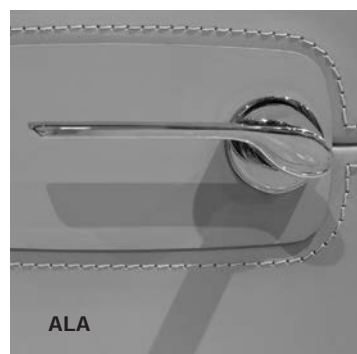

handles for sliding doors

maniglie per porte scorrevoli

manivelas para puertas correderas

варианты наборов фурнитуры для раздвижных дверей

poignées de portes coulissants

klamki dla drzwi przesuwnych

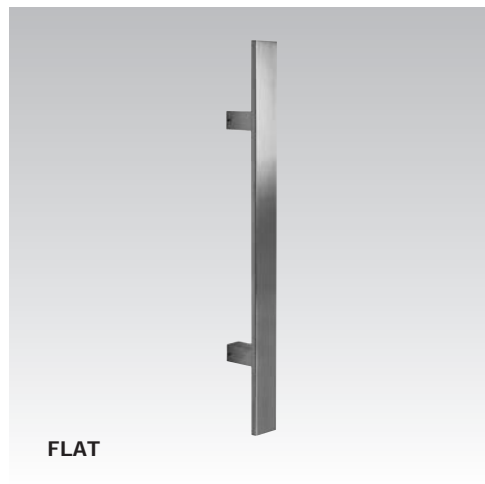
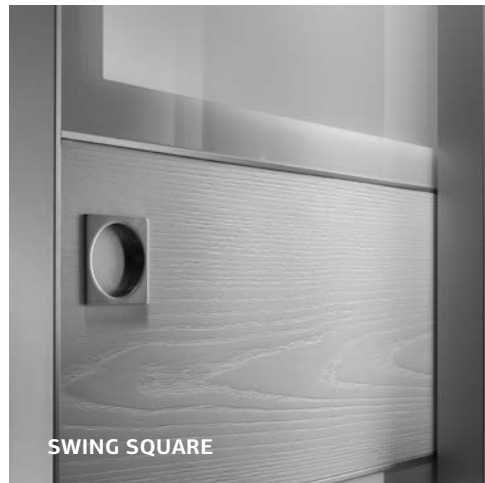

hardware kit

kit ferramenta
 kit herrajes
 набор фурнитуры
 kit quincaillerie
 zestaw okuć



cerniere a perno per porte interne complanari
pin hinges for interior flush doors
bisagras de perno para puertas interiores enrasadas
штыревые петли для внутренних компланарных дверей
charnières avec goupilles pour les portes intérieures coplanaires
zawiasy sworzeniowe do drzwi wewnętrznych współpłaszczyznowych



cerniera a sgancio brevettata
 patented lift-off hinge
 bisagra desenganchable patentada
 запатентованная отцепляемая петля
 charnière à pivot brevetée
 opatentowane zawiasy zaczepowe

TPROGRAMM STRIPE

TPROGRAMM PYRAMID

TPROGRAMM OVERSIZE



cerniere a pomella · knoblock hinges · bisagras de pomo
шарнирные петли · paumelles · zawias czopowy

EUROCENTO DECÒ

EUROCENTO STILE

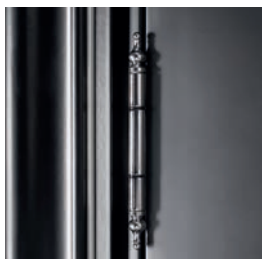

cerniere invisibili · invisible hinges · bisagras invisibles
невидимые петли · charnières invisibles · zawiasy schowane

DEA

INVERSO



magnetic lock

serratura magnetica
 cerradura magnética
 магнитный замок
 serrure magnétique
 zamek magnetyczny



Patent

Yale

WC





Barausse Product Care

kit PORTA FACILE

Brevetto Barausse

Per un montaggio rapido e preciso.

Il kit di montaggio "PORTA FACILE" è stato creato per rendere più veloci e precise le operazioni di installazione delle porte anche in assenza di falsotelaio.

Il kit è composto da un sistema di spessori da inserire tra anta e telaio prima della schiumatura per garantire il rispetto delle tolleranze.

Патент фирмы Barausse

Для быстрого и правильного монтажа.

Набор для монтажа "PORTA FACILE" был создан для того, чтобы ускорить процесс установки двери и сделать его более легким и точным даже при отсутствии фальшкороба.

Набор представляет собой систему клинышков-распорок, которые устанавливаются между дверным полотном и коробом для правильного распределения зазоров перед нанесением пенопласта.

Barausse Patent

For fast and precise fitting.

The "PORTA FACILE" fitting kit was created to make leaf installation operations quicker and more precise even when there is no counterframe.

The kit is composed by a system of shims to insert between the door and frame before foaming to guarantee compliance with the tolerances.

Brevet Barausse

Pour un montage rapide et précis.

Le kit de montage "PORTA FACILE" a été conçu pour rendre les opérations d'installation des portes plus rapides et précises, même en l'absence de contrecadre. Le kit contient un système de cales à introduire entre le vantail et le cadre avant l'injection de la mousse pour garantir le respect des tolérances.

Patente Barausse

Para un montaje rápido y preciso.

El kit de montaje "PORTA FACILE" ha sido creado para hacer más rápidas y precisas las operaciones de instalación de las puertas, incluso en ausencia de premarco.

El kit está compuesto por un sistema de suplementos que se colocan entre la hoja y el marco antes del espumado, para garantizar el respeto de las tolerancias.

Patent Barausse

Do szybkiego i dokładnego montażu.

Zestaw montażowy "PORTA FACILE" został stworzony tak, aby ułatwić i usprawnić montaż skrzydeł drzwi oraz uczynić go bardziej dokładnym nawet w przypadku braku ościeżnicy. Zestaw montażowy, składający się z systemu klinów, może być wprowadzony między drzwi a framugę jeszcze przed piankowaniem, co pozwoli na nieprzekroczenie dopuszczalnych odchyłów.

anti-humidity kit

kit anti umidità · kit antihumedad · комплект для влагоизоляции · kit anti-humidité · zestaw przeciw wilgoci

Per prevenire i danni dell'umidità.

L'umidità prodotta tra le mura domestiche in particolari situazioni, ad esempio in bagno o in cucina, può danneggiare la finitura delle porte.

Per evitare che il legno si sfaldi o che si gonfi è consigliato, all'atto dell'installazione, trattare il piede di telaio e coprifili con il prodotto antiumidità studiato per Barausse da SAYERLACK®.

Для предотвращения ущерба, наносимого влажностью.

Влажность, присутствующая в воздухе и появляющаяся на стенах домов, например, в кухнях, туалетах и ванных комнатах, может привести к повреждению облицовки дверей.

Поэтому при монтаже двери для предотвращения набухания и расщепления дерева в процессе эксплуатации, необходимо нанести слой специального состава, разработанного для фирмы Barausse SAYERLACK®.

To prevent damage from humidity.

The humidity produced inside the room in particular situations – in the bathroom or in the kitchen, for example – can damage the finish of doors.

To avoid the wood from flaking or swelling, we suggest to treat the foot of frame and architraves during installation with the anti-humidity kit developed for Barausse by SAYERLACK®.

Pour prévenir les dégâts de l'humidité.

L'humidité présente naturellement dans l'air et celle produite entre les murs domestiques, comme par exemple dans la salle de bains ou dans la cuisine, peut endommager la finition des portes.

Pour éviter que le bois ne s'effrite ou qu'il ne se gonfle il est nécessaire, au moment de l'installation, de traiter le bas du vantail, le cadre et les chambranles avec le produit anti-humidité étudié par SAYERLACK® pour Barausse.

Para prevenir los daños causados por la humedad.

La humedad producida entre las paredes domésticas en particulares situaciones (por ejemplo, en el baño o en la cocina) puede dañar el acabado de las puertas.

Para evitar que la madera se descame o se hinche, en el momento de la instalación es aconsejable tratar la parte inferior de marco y tapajuntas con el producto antihumedad especialmente estudiado por SAYERLACK® para Barausse.

Do ochrony przed wilgocią.

Wilgoć obecna w powietrzu i ścianach, a przede wszystkim w łazience i kuchni może uszkodzić drzwi.

Aby uchronić drewno przed łuszczeniem się i puchnięciem, proponujemy zastosowanie "Kitu Barausse do ochrony przed wilgocią" w trakcie instalacji drzwi przez nałożenie go na nadproże, ościeżnicę oraz pod skrzydła drzwi. Kit Antiumidità został opracowany dla firmy Barausse przez SAYERLACK®.

production site

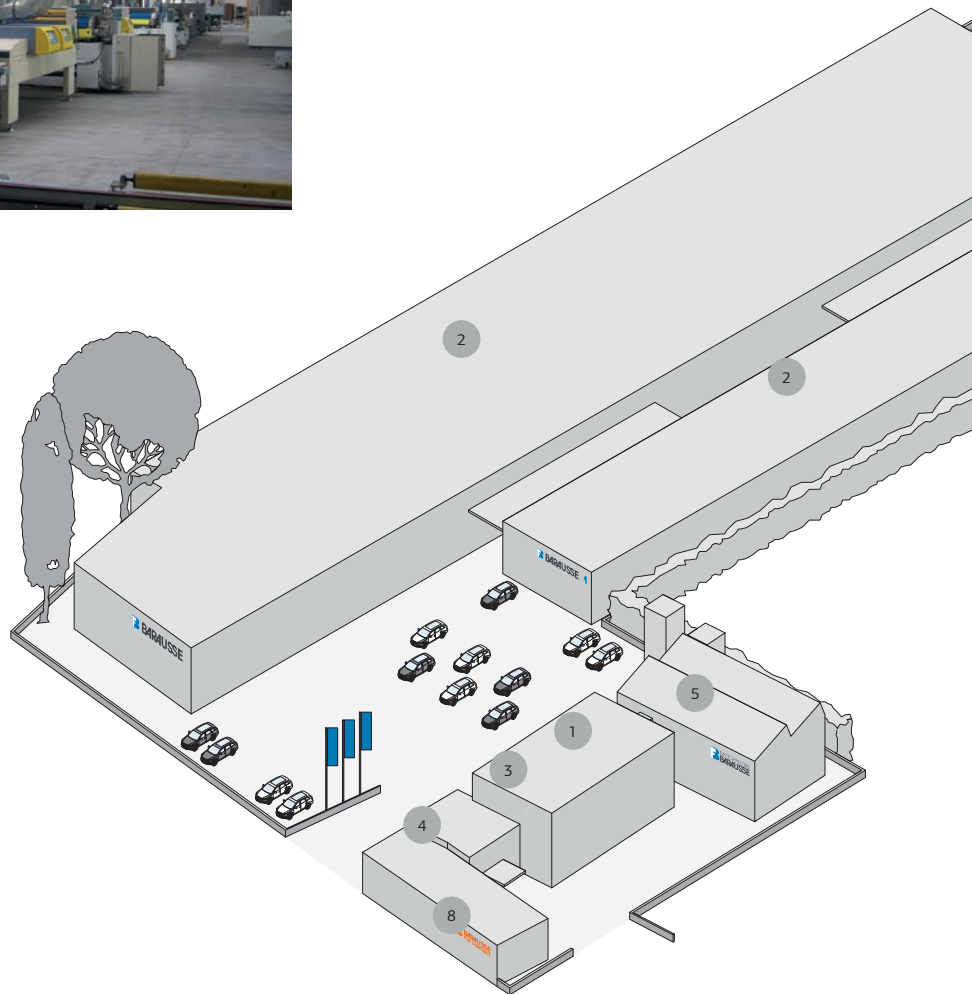

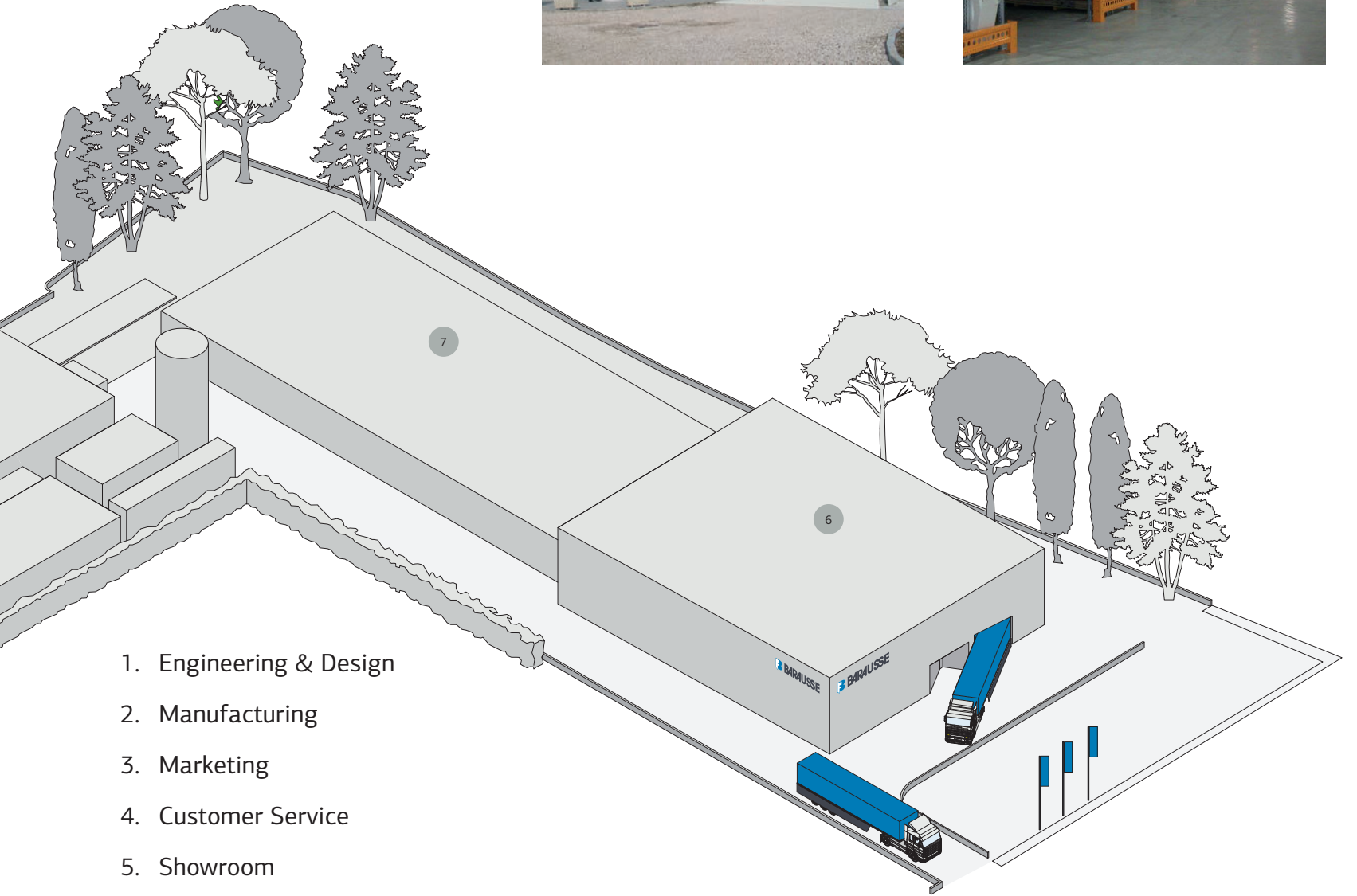

- 1. Engineering & Design
- 2. Manufacturing
- 3. Marketing
- 4. Customer Service
- 5. Showroom
- 6. Logistics
- 7. Quality Assurance & Test
- 8. Barausse For Contract



frame variants

varianti telaio

variantes marco

варианты коробов

variantes cadre

warianty rama

TB

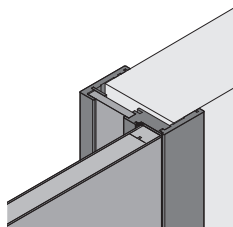

TB INVERSO

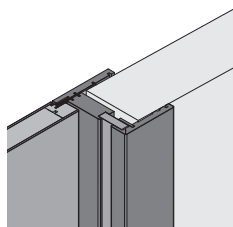

TB25

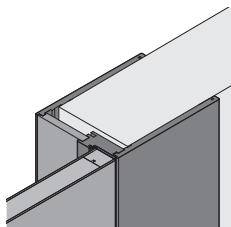

TB STILE

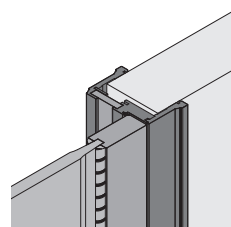

ERA STILE

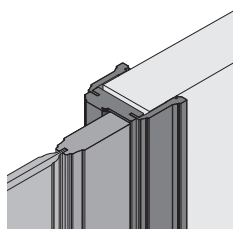

ERA PALLADIO

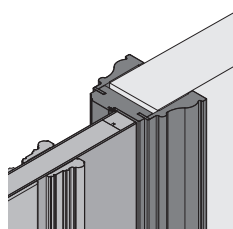

ERA PALLADIO 150

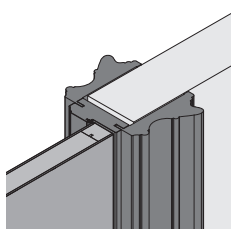

ERA DORICO

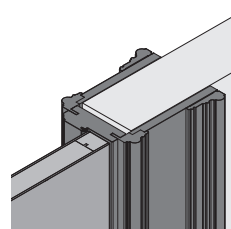

INNER

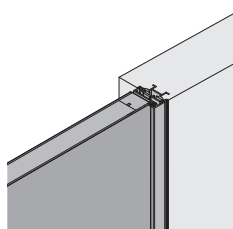

INNER2

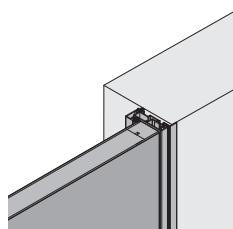

RING

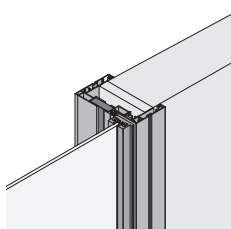

MACH2

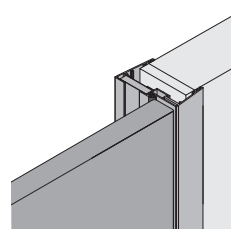

SECRET2

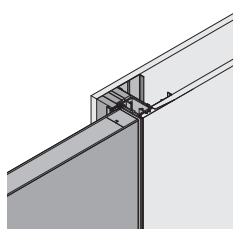



Download our product catalogue



Follow us on



www.barausse.com

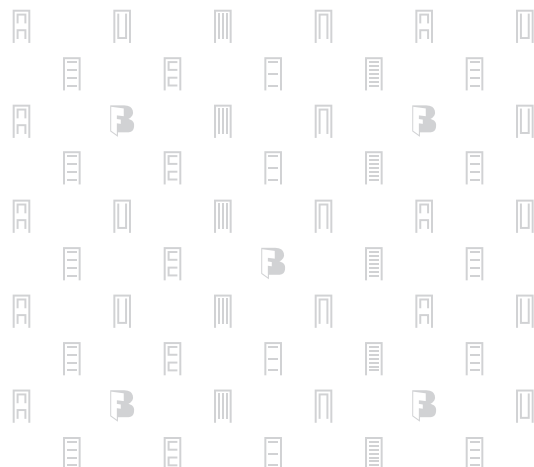

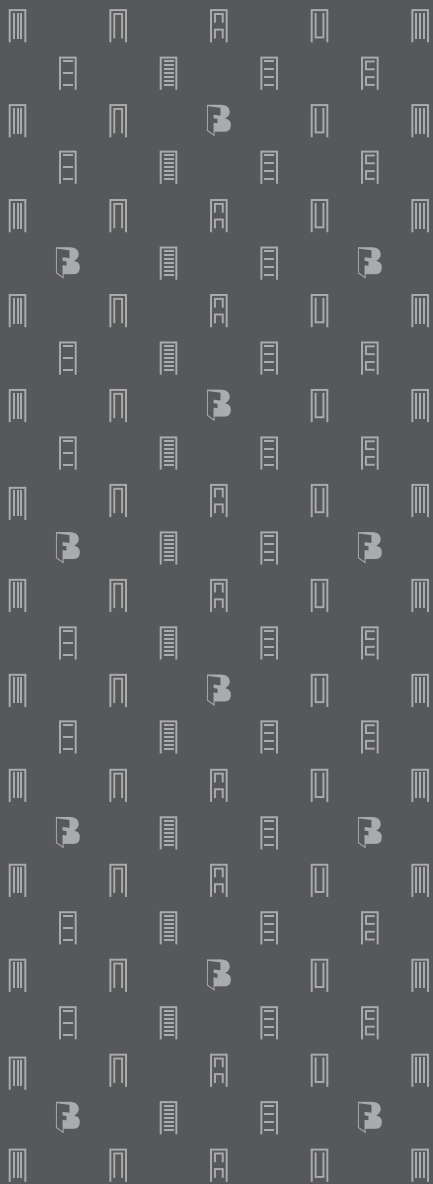

B BARAUSSE
MADE IN ITALY DOORS

BARAUSSE S.p.A.
via Parmesana, 27
36010 Monticello Conte Otto (VI) Italy
tel. +39 0444 900 000

www.barusse.com
info@barusse.com
facebook.com/leportedibarusse
[twitter @portedibarusse](https://twitter.com/portedibarusse)